

IDEAL VTS160TA

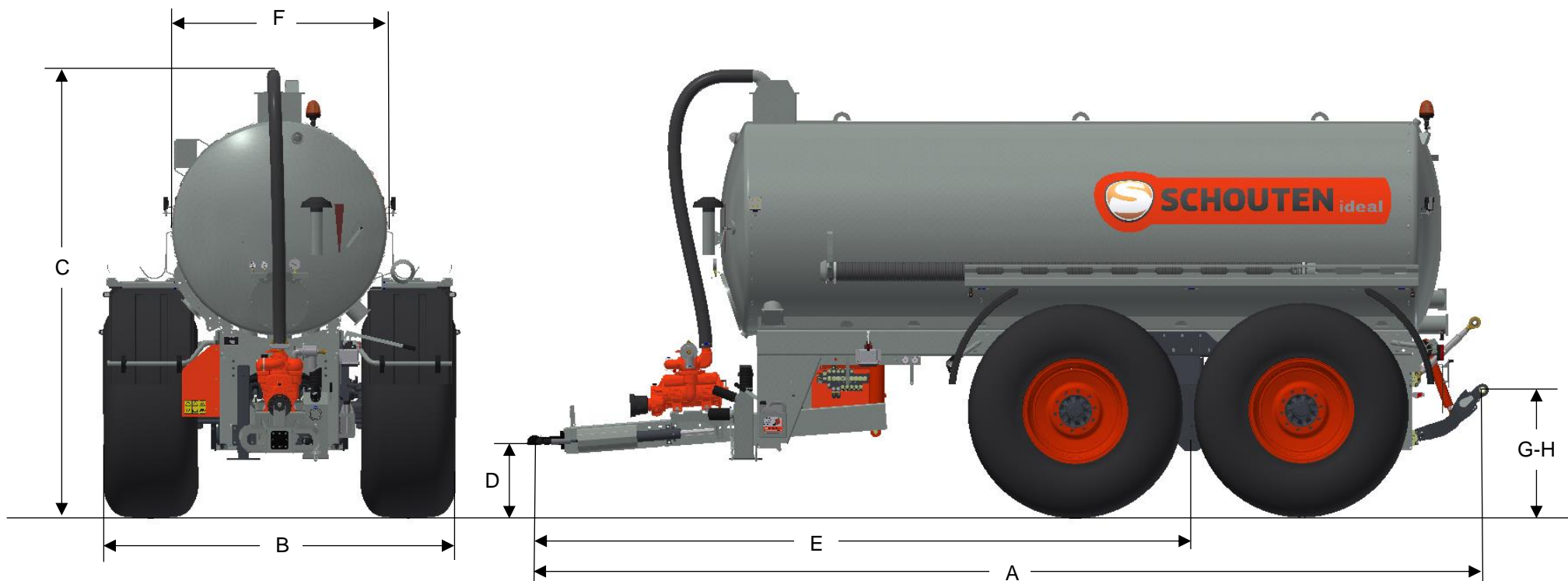

DIMENSIONS

A	LENGTH	8050 MM	E	DISTANCE HITCH - TANDEM	5560 MM
B	WIDTH	2960 MM	F	TANK DIAMETER	1900 MM
C	HEIGHT	3850 MM	G	LIFT HEIGHT MIN.	370 MM
D	HITCH HEIGHT	400-700 MM	H	LIFT HEIGHT MAX.	1070 MM

IDEAL VTS160TA

MACHINE INFORMATION

TYPE	VTS160TA
WEIGHT	8.030 KG
TANK DIMENSIONS	Ø1900X5500 MM
TANK VOLUME	16.000 LTR
LEVEL INDICATOR	FLOAT POINTER
UNDERCARRIAGE	TANDEM-AXLE
TYPE OF TANDEM	BPW BRAKED
CARRYING CAPACITY TANDEM	24.000 KG
TIRES	750/60R30.5

SUPPORT LEG	HYDR. DW
VACUUM PUMP	B&P MEC13500
CAPACITY VACUUM PUMP	13.500 L/MIN
VACUUM PUMP DRIVE	PTO 540/1000RPM
MOISTURE TRAP CAPACITY	15.500 L/MIN
LIFT POSSIBILITIES	GRASSLAND/BLACK SOIL
LIFT CAPACITY	3.500 KG
LIFT SYSTEM	4-POINTS CAT III

OPTIONS

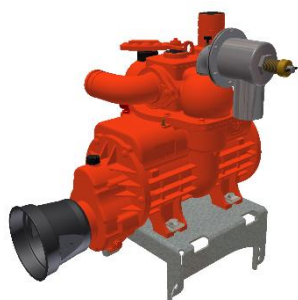

B&P MEC13500

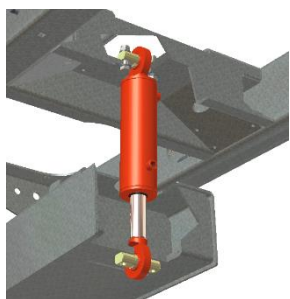

HYDR. DRAWBAR SUSPENSION

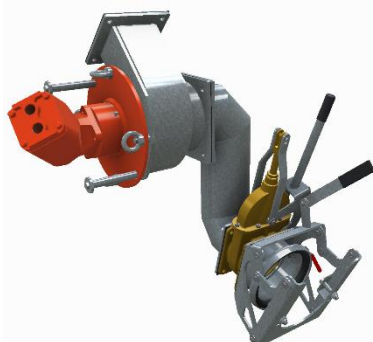

TURBO-FILLER 8-6



DOCKING FILLING ARM 8"



FILLING ARM 10" TURBO